

CAB

- Low internal noise level of just 78 dBA ensures operator comfort.
- Large areas of tinted glass allow superb all round visibility.
- Low line curved hood enhances forward visibility.
- Full depth rear window for comprehensive visibility to the trench.
- In the raised position the rear window provides ventilation yet gives protection from rain.
- Door windows can be partially or fully opened for maximum ventilation.
- Cab is ROPS and FOPS approved for maximum operator comfort.
- Well laid out controls for ease of operation.
- Touch operated switches for operator convenience.
- Instrumentation easy to clean.
- Spacious interior giving ample room to the operator at both work stations.
- Wide door opening, self-cleaning steps and large grab rails make access easy.
- Adjustable tilt steering wheel to suit all operating styles.
- Fully adjustable suspension seat with lap belt maximises operator comfort.
- Air re-circulation enables quick warm up on cold days.
- Two front and two rear defrosting vents.
- Powerful 3 speed heater supplies a further two forward and three rear vents.
- Air conditioning option available.
- Extensive stowage facilities.
- Heavy duty easy to clean rubber floor mat.
- Twin externally mounted rear view mirrors.
- Hazard warning and full lighting controls.
- Audible/visual warning covering park brake, transmission oil temp, engine coolant, engine oil pressure, hydraulic oil filter and air cleaner.
- Visual indication on 4wd engagement, hazard lights, main beam, battery charge, direction indicators and front / rear wipers.
- Adjustable rear working lights.

HYDRAULICS

- Closed centre flow sharing system.
- Twin gear pumps for simplicity and reliability.
- Power Boost to match digging power and speed to application.
- Automatic or manually activated to give more precise control as required.
- Single pedal operation of auxiliary circuit and extending dipper (opt).
- Hydraulic oil cooler reduces operating temperatures and now cleanable.
- Hydraulic tank and filter easily accessed from ground level.
- Ride control option available.

Main Pump	gpm (lpm)@2200 rpm	17.7/80
Secondary Pump	gpm (lpm)@2200 rpm	17.7/80
System Main Relief Setting	psi (bar)	3250/225
Unloader Settings	psi (bar)	3000/207

TOTAL MACHINE WEIGHT

Total Machine Weight	lb (kg)	16214 (7370)
Add/Delete		
7 in 1 Multi - Purpose *	lb (kg)	+726 (330)
7 in 1 Multi - Purpose Fork Kit	lb (kg)	+330 (150)
Deep Dig Dipper	lb (kg)	+477 (217)
Powershift	lb (kg)	+352 (160)

* 1.0m³ (1.3 yd³) Capacity

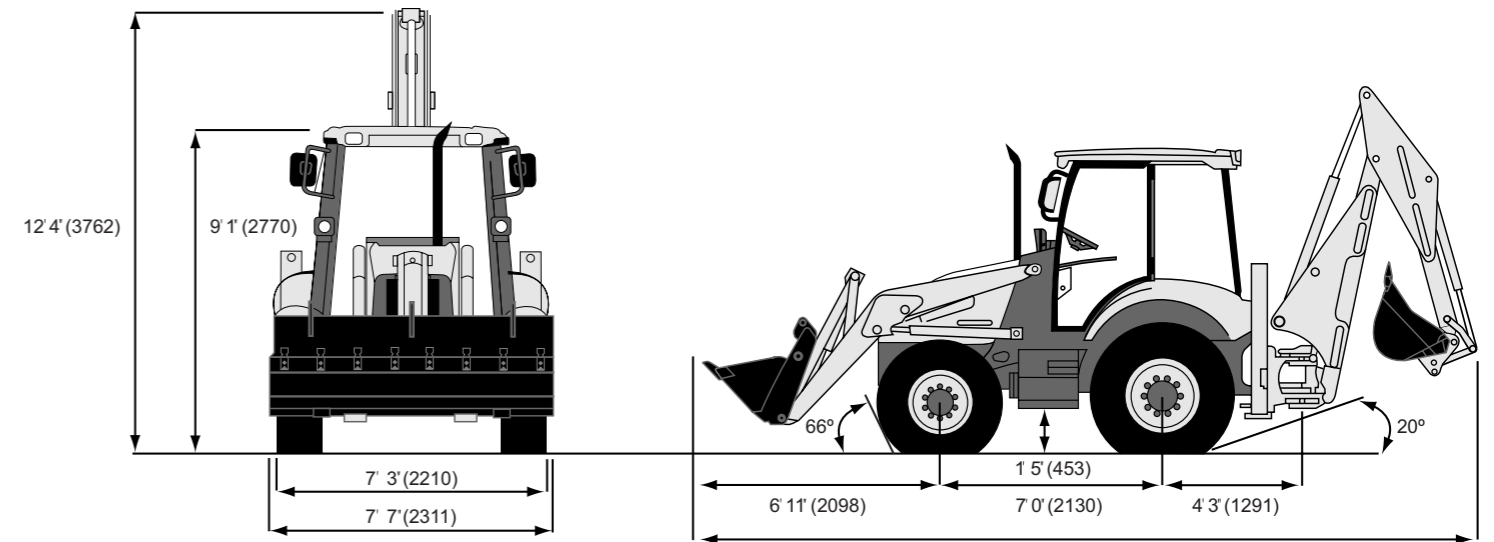

24'1" (7338) as shown
20'5" (6218) stowed

ENGINE

- Emission compliant to EC Stage 2 and EPA Tier 2.
- Higher horsepower and increased torque back up for lugging ability.
- Electric fuel lift pump for increased reliability.
- Easy service ECOplus fuel filter.
- Service periods increased to 500 hours.

		CE
Engine Model		1104C-44T
Capacity	in ³ (ltr)	269 (4.4)
Rated Speed	rpm	2200
Gross Power @ 2200 rpm	kW(hp)	74.5 (100*)
Certified Rating to ISO/TR 14396		
Derived Net Rating @ 2200 rpm to ISO 80/1269/EC	kW(hp)	70.3* (94*)
Max Torque @ 1400 rpm		
ISO/TR 14396	Nm (lbfft)	415 (305*)
ISO 80/1269/EC	Nm (lbfft)	395* (290*)

* Nominal Non-Certified Values

TRANSMISSION

- 4 speed synchro shuttle gearbox.
- Single stage torque converter with 3.01:1 stall ratio.
- High transport speed reduces highway journey times.
- Modulated forward and reverse clutch packs enable smooth direction changes.
- Available in 2WD / 4WD.
- Front console switch allows effortless engagement of 4WD on the move.

860SX 880SX			
Tyres	Front:	16/70 x 20	16/70 x 20
	Rear:	18.4 x 26	16.9 x 30
Travel Speeds:			
Forward / Reverse			
1st	Km/h (mph)	5.5 (3.9)	5.6 (3.5)
2nd	Km/h (mph)	8.8 (5.6)	9.0 (5.6)
3rd	Km/h (mph)	20.0 (12.5)	20.6 (12.8)
4th	Km/h (mph)	40.0 (25.0)	41.5 (25.8)

- 4 speed full powershift gearbox with electronic gear change.
- Twist grip lever provides effortless operation.
- Push button kickdown facility for added traction.
- Semi-automatic shifting between 3rd and 4th speeds.

860Elite 880Elite			
Tyres	Front:	16/70 x 20	16/70 x 20
	Rear:	18.4 x 26	16.9 x 30
Travel Speeds Forward			
1st	km/h(mph)	5.7 (3.6)	5.7 (3.8)
2nd	km/h(mph)	10.8 (6.7)	10.9 (6.8)
3rd	km/h(mph)	21.6 (13.4)	21.8 (13.5)
4th	km/h(mph)	40.9 (25.4)	41.1 (25.6)
Reverse			
1st	km/h(mph)	6.9 (4.3)	6.9 (4.3)
2nd	km/h(mph)	13.0 (8.1)	13.0 (8.1)

TURNING CIRCLES

		Over Tyres	Over Bucket
Without Brakes	m (ft)	7.9 (25'9")	10.6 (34'7")
With Brakes	m (ft)	7.0 (23'0")	9.7 (31'10")

Depending on tyre size

TEREX Compact
Central Boulevard
Prologis Park
Coventry
CV6 4BX
England

Tel: +44(0) 024 7633 9400

Fax: +44(0) 024 7633 9500

www.terexce.com

TEREX Compact reserve the right to change specification without notice.

Illustration may show options or accessories.

860 SX 880 SX
860 Elite 880 Elite

860 SX 880 SX
860 Elite 880 Elite

LOADER DIMENSIONS

		Standard Shovel	7-in-1 Shovel
N Dump Clearance at 45°	mm(ft)	2741 (9')	2741 (9')
Dump Height (Fully Dumped)	mm(ft)	2662 (8' 9")	2662 (8' 9")
O Loadover Height	mm(ft)	3343 (11')	3343 (11')
P Hinge Pin Height	mm(ft)	3583 (12' 8")	3583 (12' 8")
Q Pin Forward Reach	mm(ft)	352 (1' 2")	352 (1' 2")
R Reach At Ground	mm(ft)	1600 (5' 3")	1600 (5' 3")
S Max. Reach At Full Height	mm(ft)	1282 (4' 3")	1282 (4' 3")
T Reach At Full Height- 45°	mm(ft)	829 (2' 9")	829 (2' 9")
Reach At Full Height- Fully Dumped	mm(ft)	645 (2' 1")	645 (2' 1")
U Dig Depth	mm(ft)	123 (5")	123 (5")
Rollback At Ground	deg	45°	45°
Max Dump Angle	deg	57°	57°
V Overall Operating Height	mm(ft)	4263 (14')	4313 (14' 2")

LOADER PERFORMANCE

		Standard Shovel	7-in-1 Shovel
Shovel Breakout	kgf (lbf)	5575(12291)	5495 (12114)
Arms Breakout	kgf (lbf)	4952(10917)	5284 (11649)
Lift Capacity To Full Height	kg (lb)	3984 (8783)	3593 (7921)

LOADER ATTACHMENTS

		Standard Bucket	7-in-1 Bucket
860SX	Width	mm (ft) 2311 (7' 7")	2311 (7' 7")
	Capacity	m ³ (yd ³) 1.0 (1.32)	1.0 (1.32)
	Weight	kg (lb) 400 (880)	730 (1606)
860ELITE	Width	mm (ft) 2387 (7' 10")	2387 (7' 10")
	Capacity	m ³ (yd ³) 1.2 (1.56)	1.2 (1.56)
	Weight	kg (lb) 430 (946)	767 (1687)

FORKS

		1.0m ³	1.2m ³
Fork Length	mm (ft)	1067 (3' 6")	1067 (3' 6")
Section Width	mm (ins)	80 (3")	80 (3")
Assembly Weight	kg (lb)	150 (330)	153 (336)
Max. Operating Height	mm (ft)	3130 (10' 3")	3192 (10' 6")
Reach At Ground Level	mm (ft)	2680 (8' 10")	2664 (8' 9")
Reach At Full Height	mm (ft)	2232 (7' 4")	2251 (7' 5")
S.W.L. At 500mm Load Centre	kg (lb)	1000 (2204)	1000 (2204)

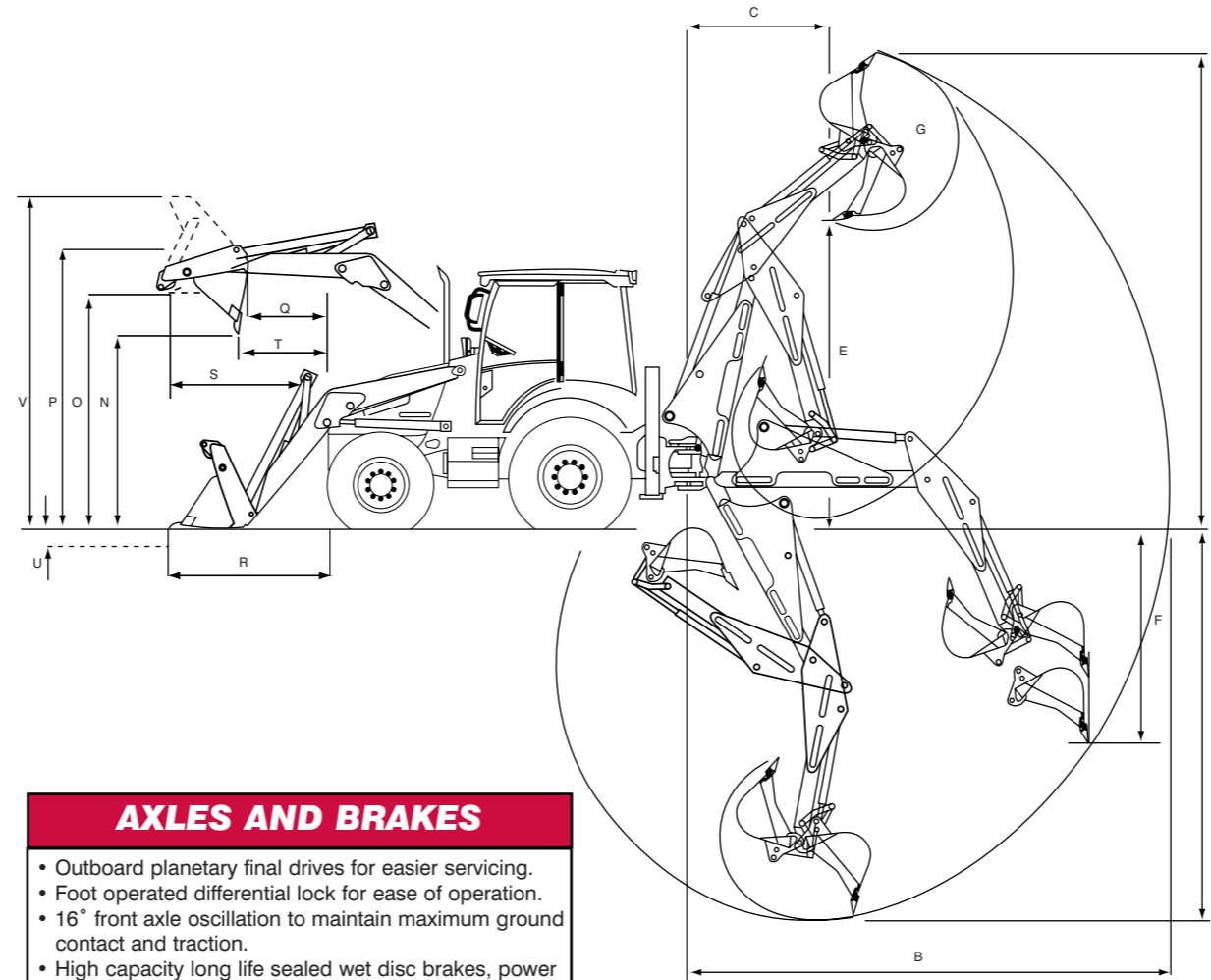

AXLES AND BRAKES

- Outboard planetary final drives for easier servicing.
- Foot operated differential lock for ease of operation.
- 16° front axle oscillation to maintain maximum ground contact and traction.
- High capacity long life sealed wet disc brakes, power boosted standard.
- Self-equalizing and self adjusting.
- Friction area per brake assembly 728cm² (113in²).
- Selectable 2 or 4 wheel braking.

Axle Ratings	Tyres	SAE J43
Front kg (lbs)	16/70 x 20	6300 (13860)
Rear kg (lbs)	16.9 x 30	6155 (13541)

CAPACITIES

	ltrs (gals)	130 (29)
Fuel Tank	ltrs (gals)	16.0 (3.5)
Engine Coolant	ltrs (gals)	8.5 (1.9)
Engine Oil (inc. Filter)	ltrs (gals)	15.0 (3.3)
Transmission	ltrs (gals)	23.0 (5.1)
Transmission Powershift	ltrs (gals)	17.5 (3.9)
Rear Axle	ltrs (gals)	12.5 (2.7)
Front Axle	ltrs (gals)	143 (31.7)
Hydraulic System	ltrs (gals)	

ELECTRICS

- 12 volt system.
- Battery step mounted for good access.
- Low maintenance battery.
- 75 A alternator. 100A Option.
- Connectors sealed against water and dust.
- 33 circuit fuses.
- 25 circuit relays.
- Battery isolator.

BACKHOE DIMENSIONS

		Standard Dipper	Deep Dig Dipper	
			Ret	Ext
A Dig Depth -				
Maximum SAE	mm (ft)	4438 (14' 7")	4438 (14' 7")	5782 (19')
2ft Flat Bottom SAE	mm (ft)	4422 (14' 6")	4422 (14' 6")	5771 (18' 11")
B Reach - Ground				
Level To Slew	mm (ft)	5726 (18' 9")	5726 (18' 9")	7017 (23')
C Loading Reach	mm (ft)	1996 (6' 7")	1996 (6' 7")	2924 (9' 7")
D Operating Height	mm (ft)	5692 (18' 8")	5692 (18' 8")	6670 (21' 11")
E Loading Height SAE	mm (ft)	3586 (11' 9")	3586 (11' 9")	4564 (15')
Max Load Height	mm (ft)	3904 (12' 10")	3904 (12' 10")	4882 (16')
F Maximum Straight				
Wall Dig Depth	mm (ft)	2569 (8' 5")	2569 (8' 5")	3958 (13')
G Bucket Rotation -	deg	194°	194°	194°
Total Side Shift	mm (ft)	1286 (4' 3")	1286 (4' 3")	1286 (4' 3")
Stabiliser Spread	mm (ft)	2115 (6' 11")	2115 (6' 11")	2115 (6' 11")
Maximum Levelling				
Angle	deg	8°	8°	8°

BACKHOE PERFORMANCE

		Standard Dipper	Deep Dig Dipper	
			Ret	Ext
Slew Torque	Nm (lbfft)	16100 (11875)	16100 (11875)	16100 (11875)
Dipper Tearout	kgf (lbf)	3946 (8670)	3946 (8670)	2644 (5829)
Bucket Tearout -	kgf (lbf)	5260 (11596)	5260 (11596)	5260 (11596)
Hydraulic Lift Capacity (Including Bucket)	kg (lb)	1564 (3448)	1297 (2859)	918 (2024)

BACKHOE ATTACHMENTS

Attachments	Width	Capacity	Weight
Trench Bkts	12in (305mm)	2.94ft ³ (83ltrs)	207lb (94kg)
	18in (450mm)	4.37ft ³ (124ltrs)	247lb (112kg)
	24in (600mm)	6.51ft ³ (184ltrs)	295lb (134kg)
	24in (600mm)	8.22ft ³ (233ltrs)	295lb (143kg)
	30in (750mm)	8.74ft ³ (248ltrs)	342lb (155kg)
	36in (900mm)	11.03ft ³ (312ltrs)	390lb (177kg)
Ditch cleaning	60in (1525mm)	8.0ft ³ (220ltrs)	320lb (145kg)
	72in (1830mm)	10.0ft ³ (300ltrs)	388lb (176kg)
Sq hole bucket	36in (900mm)	4.41ft ³ (125ltrs)	353lb (160kg)